



S E R V E R

SERVE BETTER™

Server Express™ Pumps

MODEL 07794

Used with pouches up to
1½ gallons with 16mm fitments.

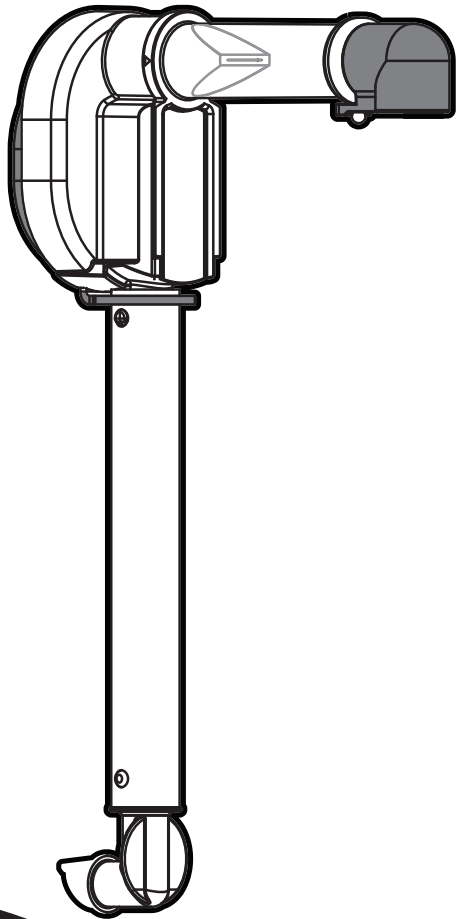
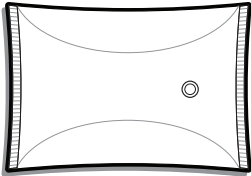

Thank You

...for purchasing our Server Express™ Pump.
Express™ pouched condiment systems are sealed
and sanitary, achieve excellent evacuation and have
only a few parts for easy clean-up.

SIMPLIFY CONDIMENT MANAGEMENT — GO POUCHED

ASSEMBLY

WASH ALL PARTS
PROPERLY BEFORE USE. See page 3.

1 INSERT PINCH VALVE

into pump housing.

TIP: Squeeze the pinch valve open before installation to ensure it isn't stuck shut.

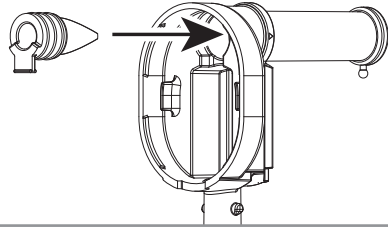

2 INSTALL DOME

Press dome into housing fully.
Ensure valve flap covers bottom opening.

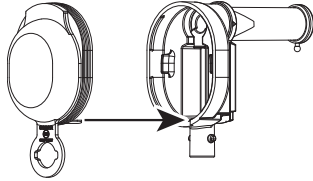

Wrap loop around lower opening to secure dome.

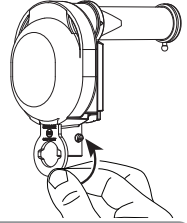

3 INSTALL TUBE

Lubricate with a small amount of clean water.
Rotate and position until both pegs on housing fit into holes on tube.

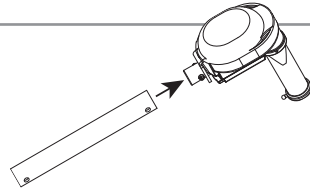

4 INSERT CONNECTOR

Lubricate with a small amount of clean water.
Rotate and position until both pegs on connector fit into holes on tube.
Connector must point away from end of discharge tube.

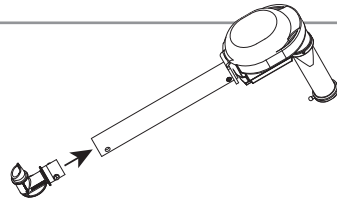

5 SELECT DISCHARGE FITTING

CONSISTENCY OF
WHAT YOU DISPENSE

SUGGESTED
FITTING SIZE

THIN (hot sauce) SMALL
THICK (ketchup or mustard)..... MEDIUM
PARTICULATES (relish or tartar sauce) LARGE

Fittings are marked small, medium or large on bottom.

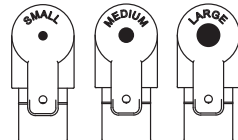

6 INSERT DISCHARGE FITTING

into pump housing discharge tube.
Place loop of fitting around peg on end of discharge tube to secure.

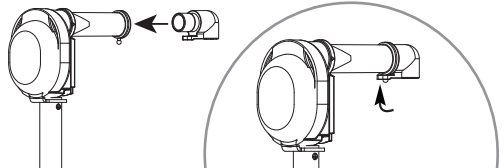

SAFETY



According to food and safety regulations, most foods must be stored and/or served at certain temperatures or they could become hazardous. Check with local food and safety regulators for specific guidelines. Server Products, Inc. cannot be responsible for the serving of potentially hazardous product.

IMPORTANT

Clean, rinse, sanitize, and dry parts daily or regularly to comply with local sanitization requirements.



NSF International (National Sanitation Foundation) lists this pump as: "Not acceptable for dispensing potentially hazardous foods."



ADA
compliant

DISASSEMBLY

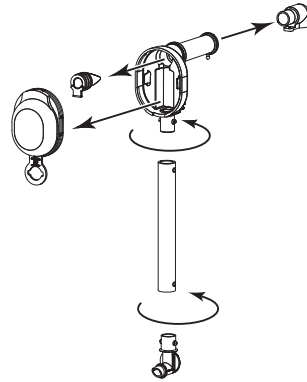
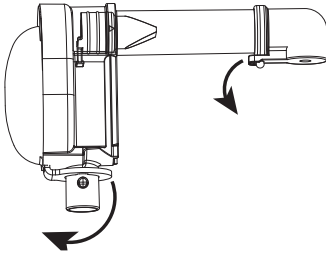

CLEANING

1

FLUSH & RINSE

all pump surfaces with hot water. Place lower end of pump into container of hot water and operate pump until all remaining product is expelled and only hot water is discharged.

2

DISASSEMBLE & CLEAN

all washable parts with soap and hot water. Use brush to clean any confined areas.

3

RINSE

fully with clear water.

4

SANITIZE

all parts according to local sanitization requirements. All parts in contact with food must be sanitized.

5

AIR DRY

all parts fully.



YES!

Use dishwashing soap, hot water and nylon brush

- Dishwasher safe
- Do not use abrasive, caustic or ammonia based cleansers.
- Do not use cleansing agents with high concentrations of acid, alkaline or chlorine.
- Do not use metal scrapers or cleaning pads that could scratch surfaces.

MODEL 07794

PART	QTY	DESCRIPTION
------	-----	-------------

07383	1	PUMP DOME, BLACK
07798	1	LARGE PINCH VALVE
07388	1	PUMP HOUSING
07089	1	7" TUBE
07381	1	CONNECTOR, 16MM
07795	1	DISCHARGE FITTING, .156, SM.
07796	1	DISCHARGE FITTING, .256, MED.
07797	1	DISCHARGE FITTING, .394, LG.

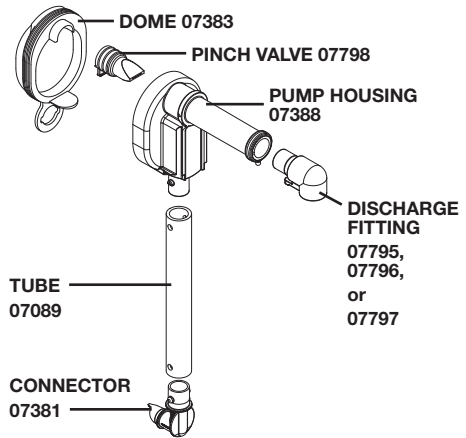

TROUBLESHOOTING

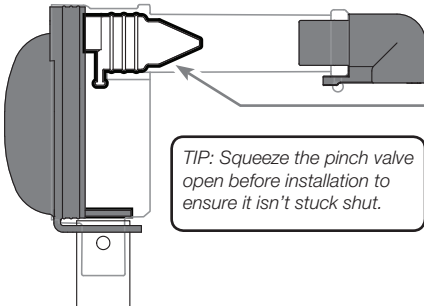

DIFFICULT TO ATTACH PARTS?

- Wet parts with clean water to help fit.

PRODUCT DOESN'T PUMP?

- Ensure pinch valve is inserted in housing.
- Ensure connector is snapped fully in place to fitment in pouch.
- Ensure pump is properly installed in unit.
- Clean pump thoroughly.

DOMES POPS OFF?

- Clean thoroughly. Food residue could prevent a tight seal between dome and housing.
- Ensure dome edges are flush with housing.

SERVER PRODUCTS LIMITED WARRANTY

2
YEAR
WARRANTY



Server Products equipment is backed by a two-year limited warranty against defects in materials and workmanship.

For complete warranty information go to:

www.Server-Products.com

GENERAL SERVICE, REPAIR OR RETURNS

Before sending any item to Server Products for service, repair, or return, contact Server Products customer service to request a **Return Authorization Number**. Merchandise must be sent to Server Products with this number. Service is extremely prompt. Typically, units are repaired and ship out within 48 hours of receipt.

Merchandise being returned for credit must be in new and unused condition and not more than 90 days old and will be subject to a 20% restocking charge.

HELP or ORDERING REPLACEMENT PARTS

Server Products Inc.

3601 Pleasant Hill Road
Richfield, WI 53076 USA



262.628.5600 | 800.558.8722



SPSALES@SERVER-PRODUCTS.COM

Please be prepared with the **Part Numbers** for your items. Individual part numbers are listed above.