



01676-REVA_080414_ENGLISH

S E R V E R

SERVE BETTER™

SERVER EXPRESS™

**SE-SS
SINGLE DI, LJS-TARTAR
07808**

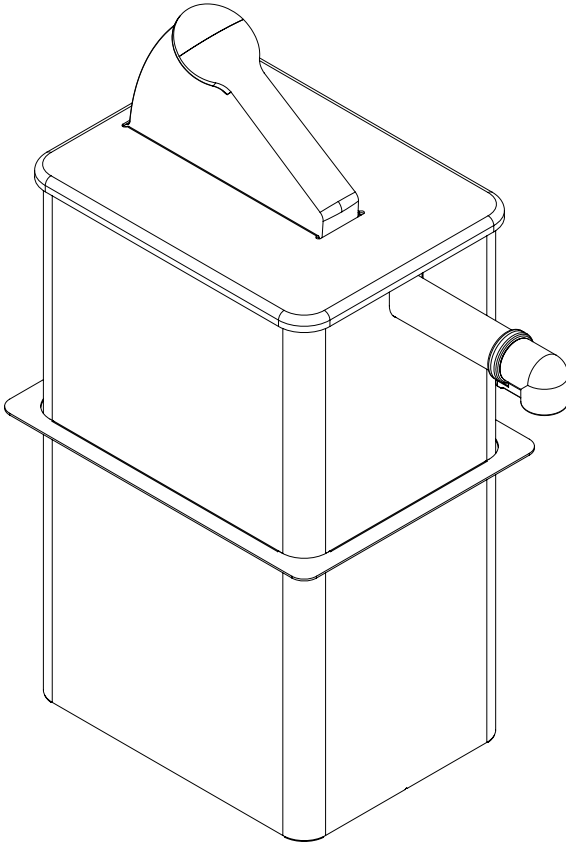

**SERVER EXPRESS™
SINGLE DI, LJS-TARTAR
07808**

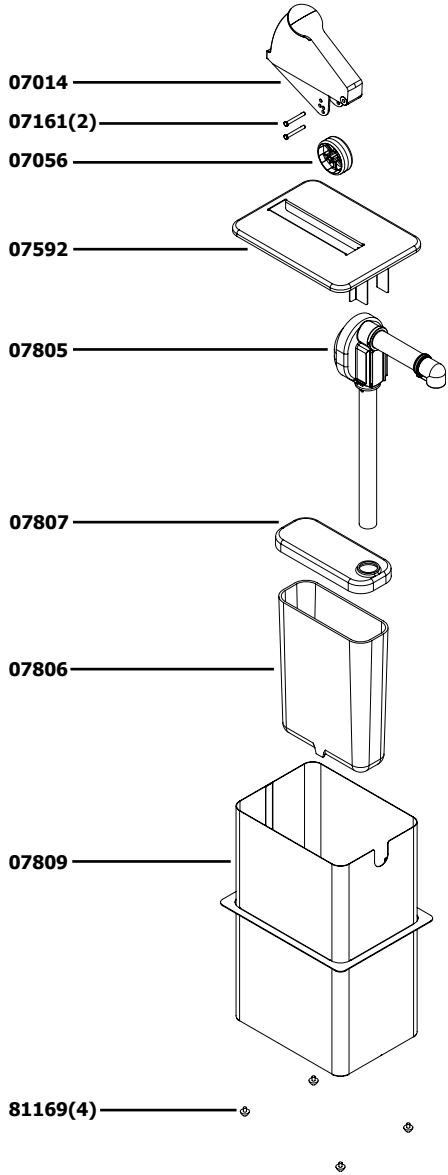

07014	LEVER
07056	ROLLER
07161	PIN, HINGE, SLIC
07592	LID
07805	PUMP, 55 DURO DOME, NO CONNECTOR
07806	JAR, FOUNTAIN, PLSTC, 2/3, SHORTEN
07807	LID, 2/3, WHITE-PLASTIC, NO THREADS
07809	SHROUD ASSEMBLY
81169	FOOT, W/SCREW
82049	BRUSH

**SERVER EXPRESS™ PUMP
55 DURO DOME,
NO CONNECTOR
07805**

Part	Description
07388	HOUSING, PUMP ASSEMBLY, CLR
07399	DOME, PUMP, .281, 55 DURO
07669	TUBE, PLASTIC, 9 1/2"
07796	FITTING, DISCHARGE, .256-MEDIUM
07798	VALVE, PINCH, ADA PUMP, LARGE

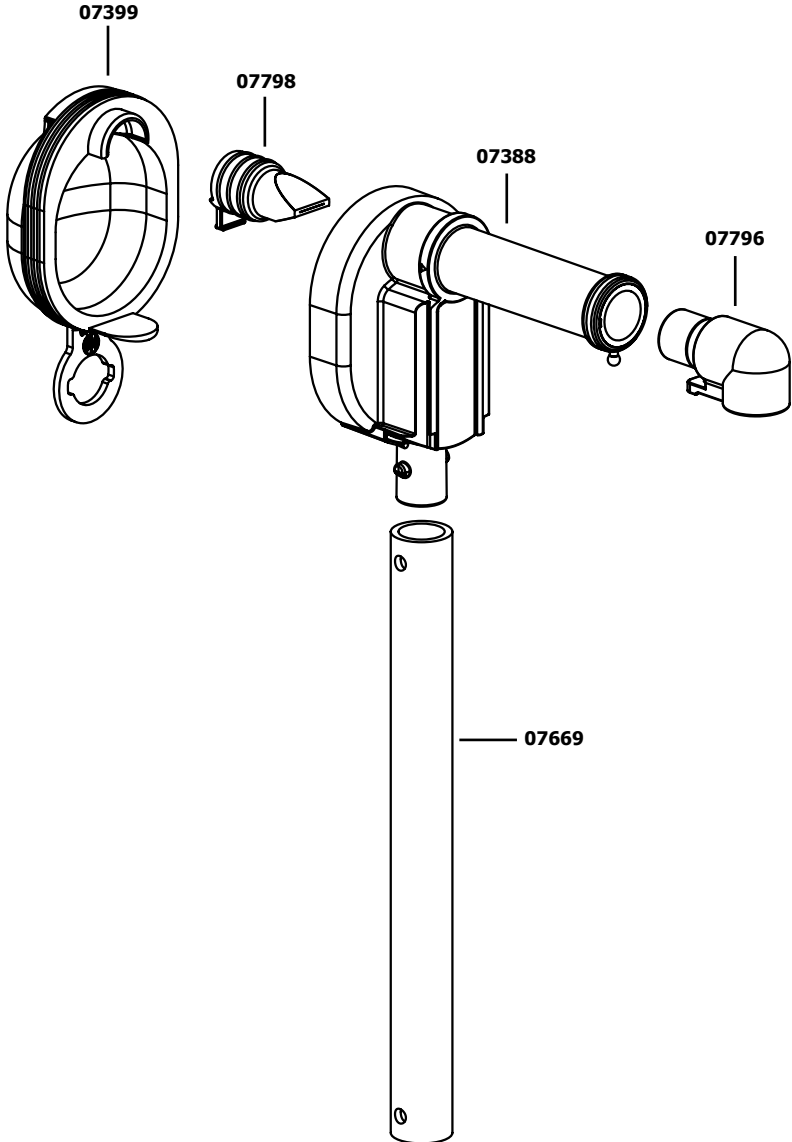

PUMP CLEANING

BEFORE FIRST USE AND AFTER USE DAILY OR REGULARLY, DISASSEMBLE AND CLEAN PARTS. FOR SAFE AND PROPER CARE, AND TO PREVENT CORROSION, OF PARTS, IT IS IMPORTANT TO CLEAN, RINSE, SANITIZE, AND DRY PARTS DAILY OR REGULARLY. FAILURE TO COMPLY WITH ANY OF THESE INSTRUCTIONS MAY VOID UNIT WARRANTY.

- 1 FLUSH AND RINSE ALL INSIDE AND OUTSIDE SURFACES OF PUMP THOROUGHLY WITH HOT WATER.
 - Place lower end of pump into container of hot water and operate pump until all (if any) remaining product is expelled and only hot water flows from discharge tube. Then remove pump from container of water to disassemble.
- 2 DISASSEMBLE PUMP.
- 3 WASH CLEAN ALL PARTS WITH DISHWASHING DETERGENT AND HOT WATER.
 - Clean all confined areas with any supplied brush(es).
 - Do not use scrapers, steel pads, steel wool, or other cleaning tools that can scratch surfaces.
 - Mildly abrasive NYLON or brass brush may be used to remove any stubborn food or mineral deposits on interior surfaces of unit.
 - Do not use abrasive cleansers.
 - Do not use caustic cleansers.
 - Do not use cleansing agents with high concentrations of acid, alkaline or chlorine.
 - Do not use ammonia based cleansers.
- 4 FULLY RINSE ALL WASHED PARTS THOROUGHLY WITH CLEAR WATER.
 - To prevent corrosion on parts, it is important to thoroughly and fully rinse washed parts.
- 5 SANITIZE ALL PARTS FOLLOWING LOCAL SANITIZATION REQUIREMENTS. ALL PARTS IN CONTACT WITH FOOD MUST BE SANITIZED.
 - Allow parts to fully air dry after sanitization.
 - Dishwasher safe.

GENERAL SERVICE, REPAIR, OR RETURNS

Before sending any item to Server Products for service, repair, or return, contact Server Products customer service to request a **Return Authorization Number**. Merchandise must be sent to Server Products with this number.

Merchandise being returned for credit must be in new and unused condition and not more than 90 days old and will be subject to a 20% (percent) restocking charge. Electrical parts (thermostats, heating elements, etc.) are not returnable.

Server Products maintains a fully staffed service department with highly skilled factory trained personnel. Service is extremely prompt. Under normal circumstances, a repaired unit is shipped out the day after it is received. Labor charges are reasonable.

SERVICE

Contact your dealer or Server Products Inc. customer service department for the following:

ORDERING REPLACEMENT PARTS

Be prepared to give this information:

- Model Letters/Name/Numbers
- Part Numbers- P/N
- Series Numbers/Letters
- Part Description

This information and other important data is stamped on the lid or cylinder of pumps or on the bottom or back side of every unit.

SERVER PRODUCTS LIMITED WARRANTY

All Server Products equipment is backed by a two-year limited warranty against defects in materials and workmanship. For complete warranty information go to: www.server-products.com



Server Products Inc.

3601 Pleasant Hill Road
Richfield, WI 53076 USA



262.628.5600



800.558.8722



262.628.5110



spsales@server-products.com



www.server-products.com