

SERVER

• E S S E N T I A L S •

Server Express®

Used with pouches up to
1½ gallons with 16mm fitments.

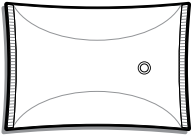

MODELS:

SE-5

SE-5DI

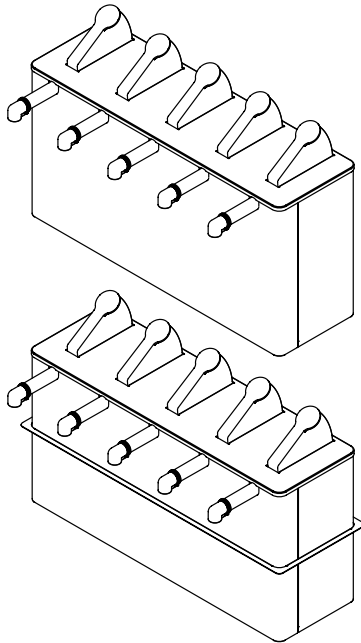

Thank You

for purchasing our Server Express® Pouched Condiment Dispenser. This portion controlled unit is sealed and sanitary, achieves excellent evacuation and has only a few parts for easy clean-up.

SIMPLIFY CONDIMENT MANAGEMENT— GO POUCHED

SERVER EXPRESS® MODELS

SE-5
07122
 Quintuple

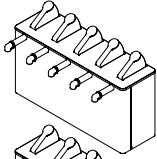

SE-5DI
07123
 Quintuple
 Drop-In

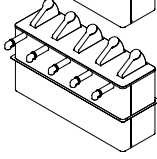

PARTS

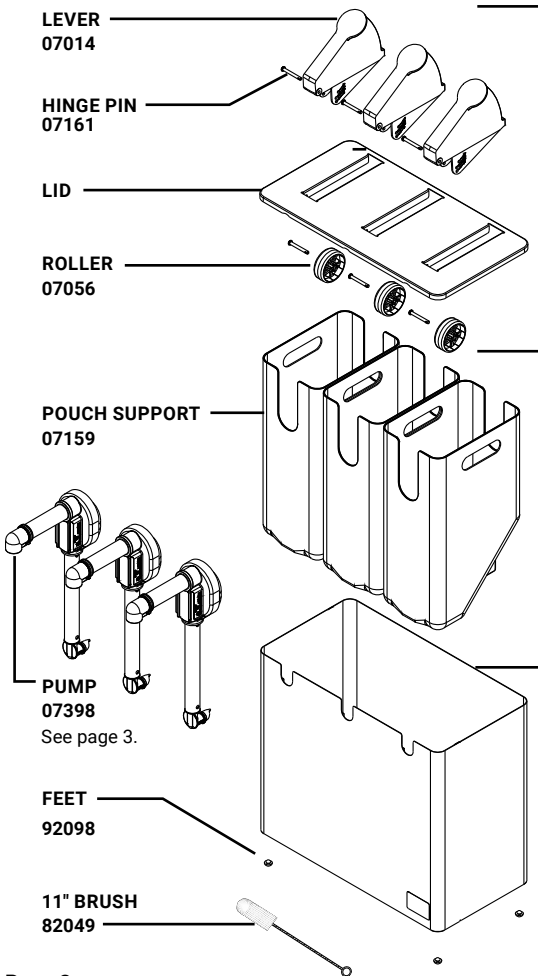

LID ASSEMBLY

MODEL(S) (ROUNDED CORNERS)	LID	LID ASSEMBLY
07122, 07123	07851	07868

OLDER MODELS (LIDS WITH SQUARE CORNERS)

07122, 07123	07104	07105
--------------	-------	-------

SHROUD

MODEL	REPLACEMENT SHROUD
07122	07856
07123	07857

SAFETY



According to food and safety regulations, most foods must be stored and/or served at certain temperatures or they could become hazardous. Check with local food and safety regulators for specific guidelines. Server Products, Inc. cannot be responsible for the serving of potentially hazardous product.

IMPORTANT

Clean, rinse, sanitize, and dry parts daily or regularly to comply with local sanitization requirements.



NSF International lists this pump as: "Not acceptable for dispensing potentially hazardous foods."

ADA
compliant

DROP-IN UNITS

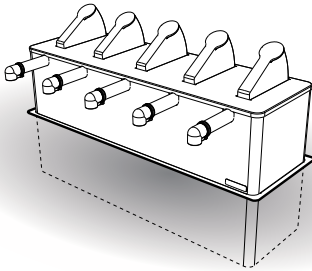

Drop-in units can be used either on a countertop surface or can be dropped into an opening in a countertop.

MODEL NUMBER

RECOMMENDED COUNTERTOP OPENING SIZE

07123 QUINTUPLE

8 1/2" x 27 3/16"

PUMP MODEL 07398

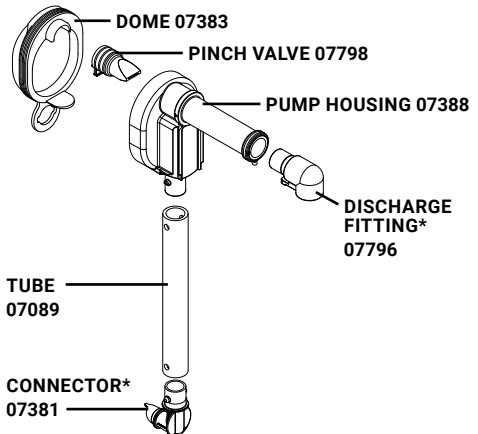
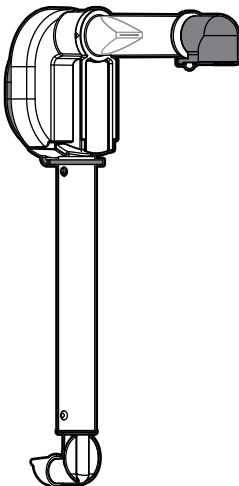

*Unit includes 2 each spare parts.

PUMP ASSEMBLY

WASH ALL PARTS
PROPERLY BEFORE USE. See page 7.

- 1** INSERT PINCH VALVE
into pump housing.

*TIP: Squeeze the pinch valve
open before installation to
ensure it isn't stuck shut.*

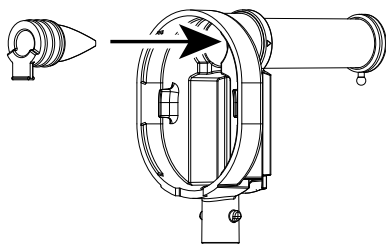

- 2** INSTALL DOME

Press dome into
housing fully.
Ensure valve flap
covers bottom
opening.

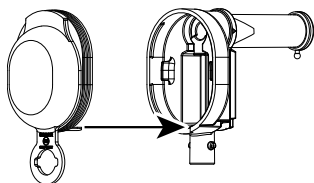

Wrap loop
around lower
opening to
secure dome.

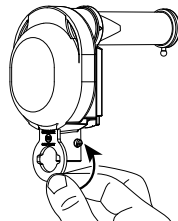

- 3** INSTALL TUBE

Lubricate with a small amount of clean water.
Rotate and position until both pegs on
housing fit into holes on tube.

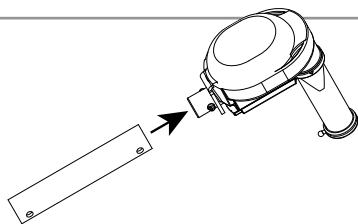

- 4** INSERT CONNECTOR

Lubricate with a small amount of clean water.
Rotate and position until both pegs on
connector fit into holes on tube.
Connector must point away from end of
discharge tube.

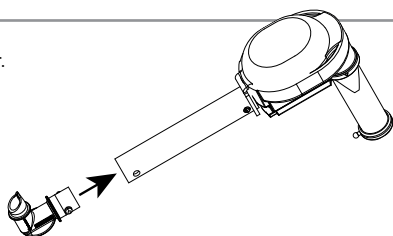

- 5** INSERT DISCHARGE FITTING

into pump housing discharge tube.
Place loop of fitting around peg on end of
discharge tube to secure.

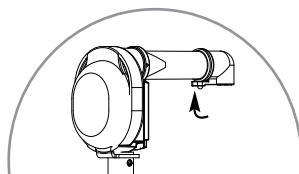

SETUP

1 ATTACH POUCHES TO PUMPS

Firmly press piercing connector into center of pouch fitment.
An audible click indicates a secure connection.

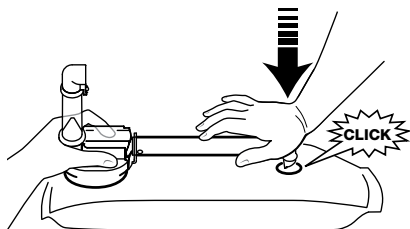

2 INSTALL PUMPS

Slide pouch and pump into pouch support within shroud.
Align pump guides into slots in shroud.

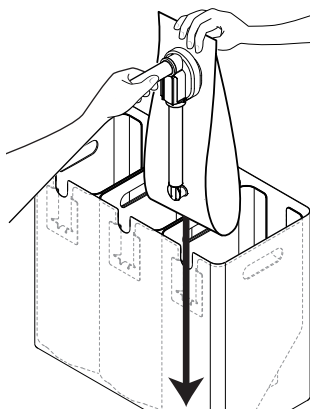

3 PLACE LID ON TOP

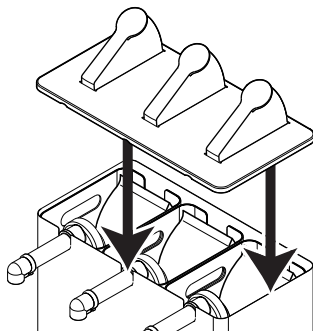

4 PRIME PUMPS

Press lever several times until you see product in discharge tube.

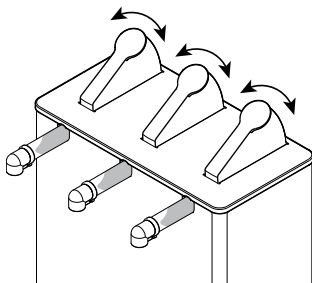

TAKE-DOWN & DISASSEMBLY

- 1 REMOVE LID
- 2 REMOVE PUMP & POUCH
- 3 DETACH PUMP FROM POUCH
- 4 FLUSH & RINSE PUMP

Place lower end of pump into container of hot water. Pump until all remaining product is expelled and only water flows from discharge tube.

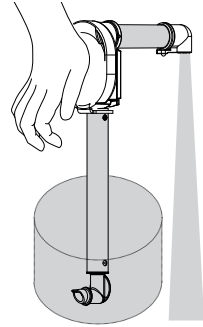

- 5 DISASSEMBLE

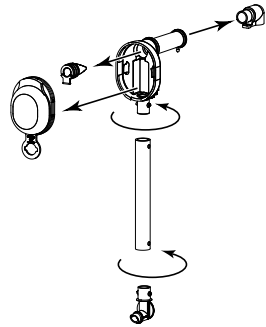
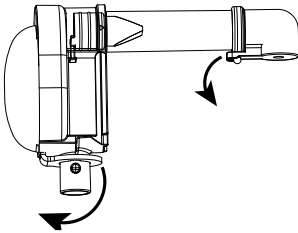

PORTION CONTROL

THE LID IS SET TO DELIVER 1 OZ PORTIONS.

**If lid reassembly is needed,
or to specify a different portion size:**

One hinge pin attaches lever to lid.

Second hinge pin attaches roller to lever.
(Controls portion dispensed.)

Install hinge pin through center
roller hole and desired portion
hole on lever.

Pin snaps into place.

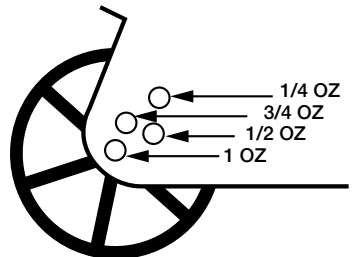
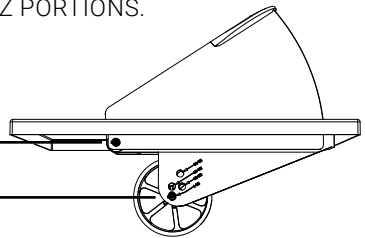
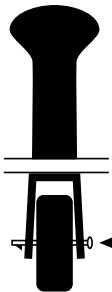

CLEANING

1

CLEAN

After disassembling, clean all washable parts with soap and hot water.

2

RINSE

fully with clear water.

3

SANITIZE

all parts according to local sanitization requirements. All parts in contact with food must be sanitized.

4

AIR DRY

all parts fully.



YES!

Use dishwashing soap and hot water

- External surfaces may be wiped clean with a clean damp cloth.
- Glass and surface cleaners approved for use in food contact areas may be used.
- Do not use abrasive, caustic or ammonia based cleansers.
- Do not use metal scrapers or cleaning pads that could scratch surfaces.

Pump cleaning

- Use nylon brush to clean any confined areas.
- Pump components are dishwasher safe.
- Refer to instruction manual provided with pump.

CARE OF STAINLESS STEEL

This unit is constructed with stainless steel— one of the best materials for food serving and storage.

If you notice corrosion beginning on any stainless steel surface, you may need to change the cleansing agent, sanitizing agent, or the cleaning procedures you are using.

- A mildly abrasive nylon or brass brush may be used to remove any stubborn food or mineral deposits on interior surfaces of unit.
- Fully rinsing and drying all parts can help prevent corrosion. Elements and minerals in tap water can accumulate on stainless steel parts and create corrosion.
- Do not use products containing acids, alkalines, chlorine, or salt. These agents can corrode stainless steel.

TROUBLESHOOTING

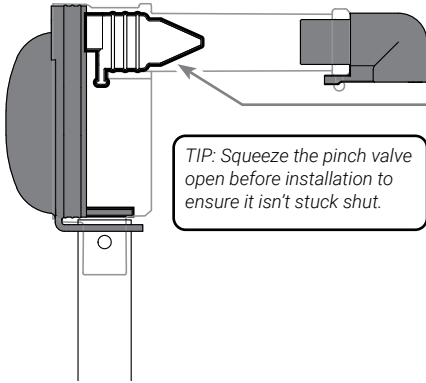

DIFFICULT TO ATTACH PARTS?

- Wet parts with clean water to help fit.

PRODUCT DOESN'T PUMP?

- Ensure pinch valve is inserted in housing.
- Ensure connector is snapped fully in place to fitment in pouch.
- Ensure pump is properly attached to pouch.
- Clean pump thoroughly.
- Ensure pump is properly installed into retaining slots inside front wall of shroud.

DOMES POP OFF?

- Clean thoroughly. Food residue could prevent a tight seal between dome and housing.
- Ensure dome edges are flush with housing.

SERVER PRODUCTS LIMITED WARRANTY

2
YEAR
WARRANTY

This Server product is backed by a two-year limited warranty against defects in materials and workmanship. See Server-Products.com for details.

GENERAL SERVICE, REPAIR OR RETURNS

Before sending any item to Server Products for service, repair, or return, contact Server Products customer service to request a **Return Authorization Number**. Merchandise must be sent to Server Products with this number. Service is extremely prompt. Typically, units are repaired and ship out within 48 hours of receipt.

Merchandise being returned for credit must be in new and unused condition and not more than 90 days old and will be subject to a 20% restocking charge.

NEED HELP?

Server Products Inc.
3601 Pleasant Hill Road
Richfield, WI 53076 USA

Chat with us!
spsales@server-products.com
262.628.5600 | 800.558.8722

Please be prepared with your **Model, P/N** and **Series** located on the lid or base of the unit.

Example:

MODEL XXXX P/N #####		SERIES ##X ##X
-------------------------------	---	-------------------

SERVER
INTELLIGENT BY DESIGN