

1 START HERE - PARTS BAG IN BIN (07811)

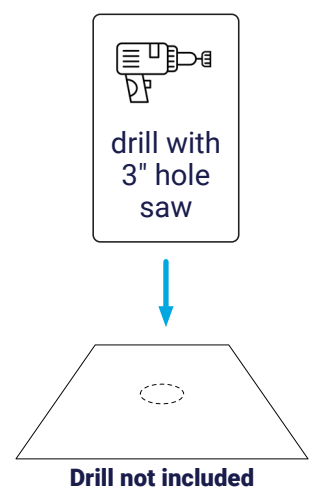

2

- (1x) 101685 (if included)
- (1x) 101300

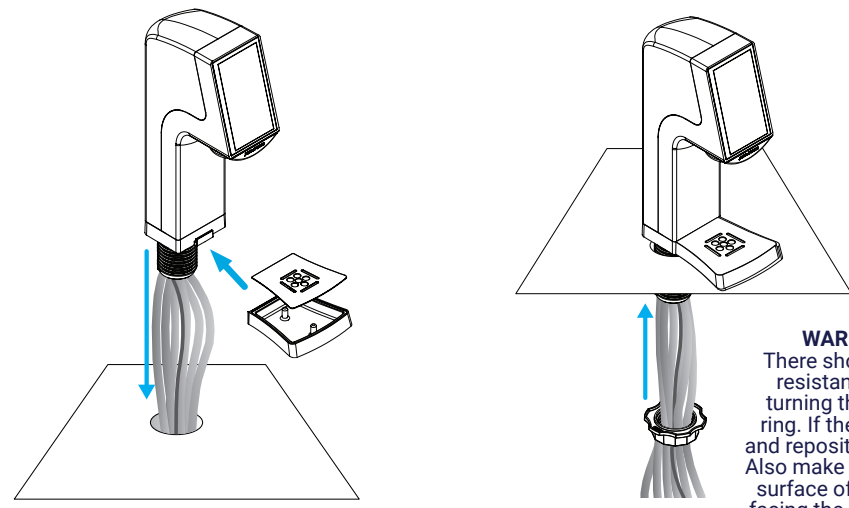

3

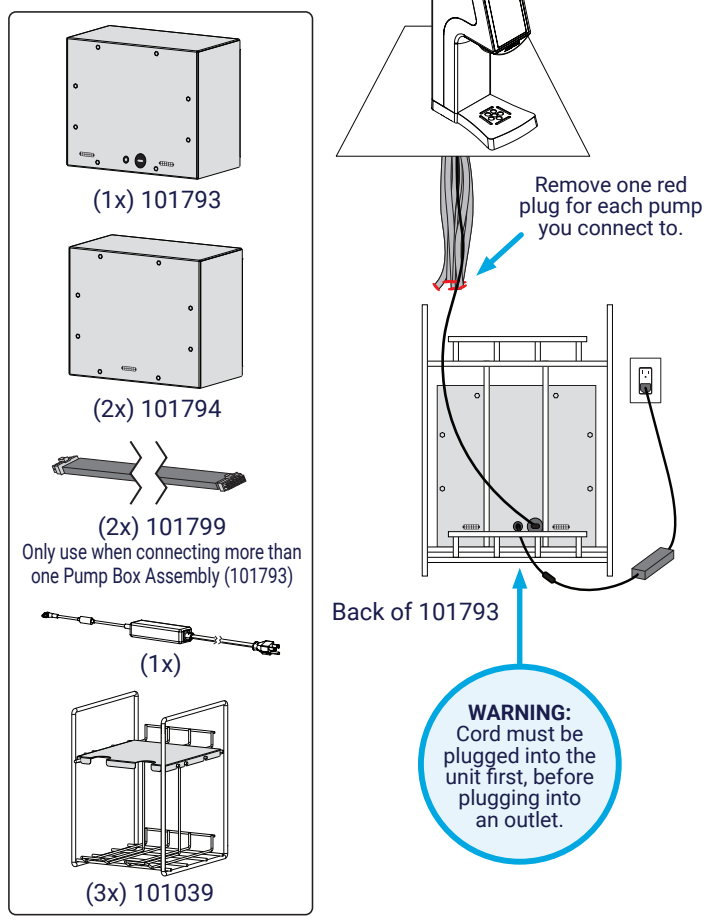

4

- (18x) 101066
- (6x) 101055 Short Tube
- (6x) 101322
- (6x) 101050
- (6x) 101465
- (6x) 85264

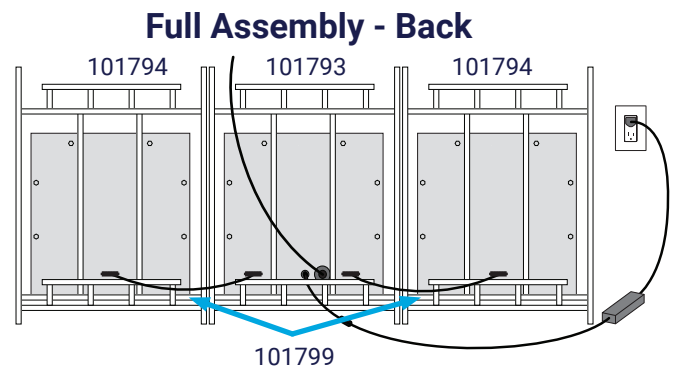
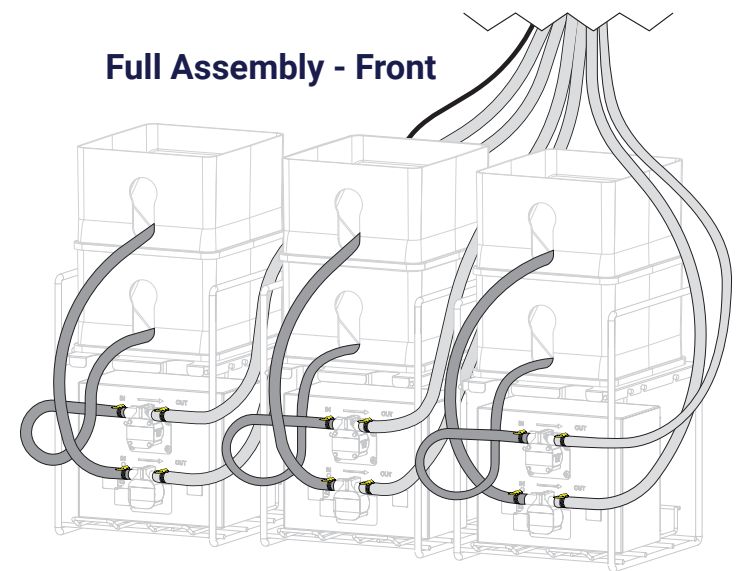
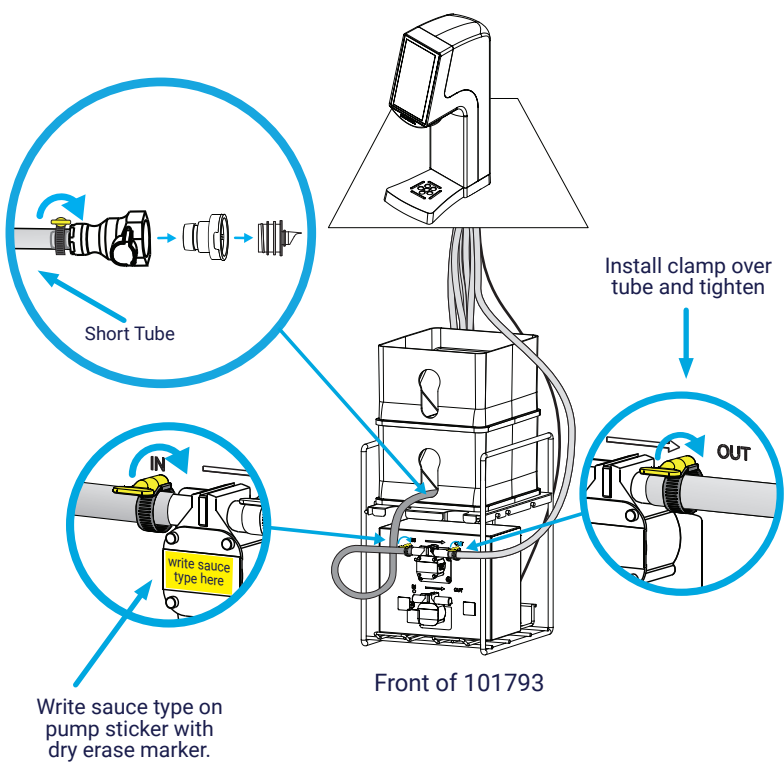

Before starting setup, you will need:

- 4L of Kay-5 cleaning solution per line or 4L of detergent water solution per line
- Empty container for flushed sanitizer/cleaner solution
- 2L of rinse sanitizer per line if cleaning with detergent
- Clean, dry towels
- Dry erase markers



SETUP

Follow prompts to continue



Scan for Multi+ Condiment Dispenser manual or visit https://server-products.com/lxDM_Multi.pdf

