

1 START HERE – PARTS BAG IN BIN (101681)

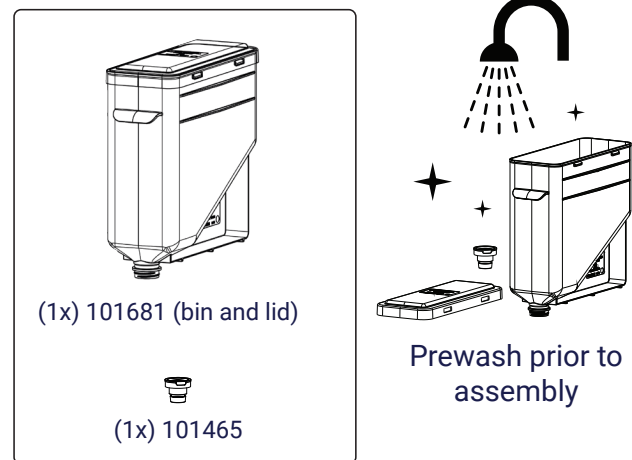

2

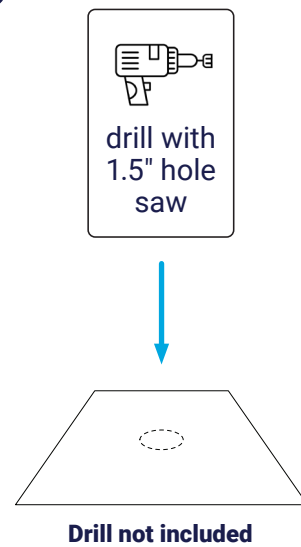

3

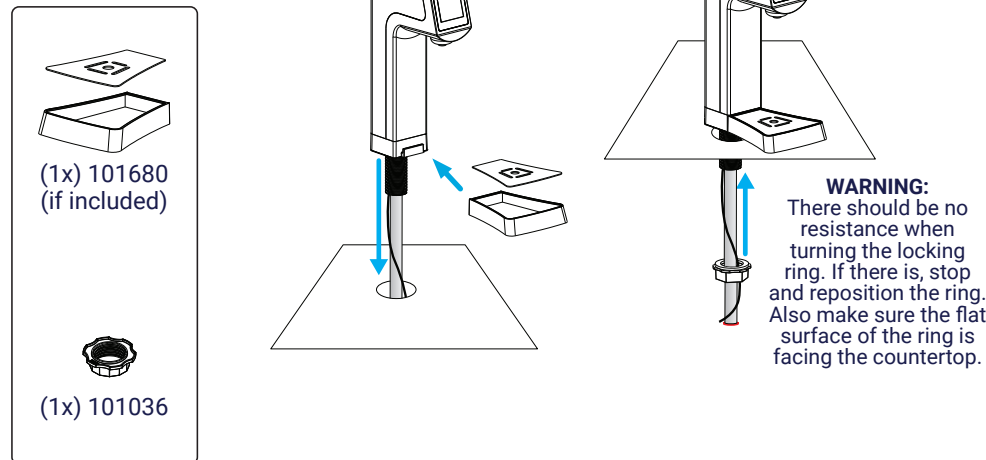

4

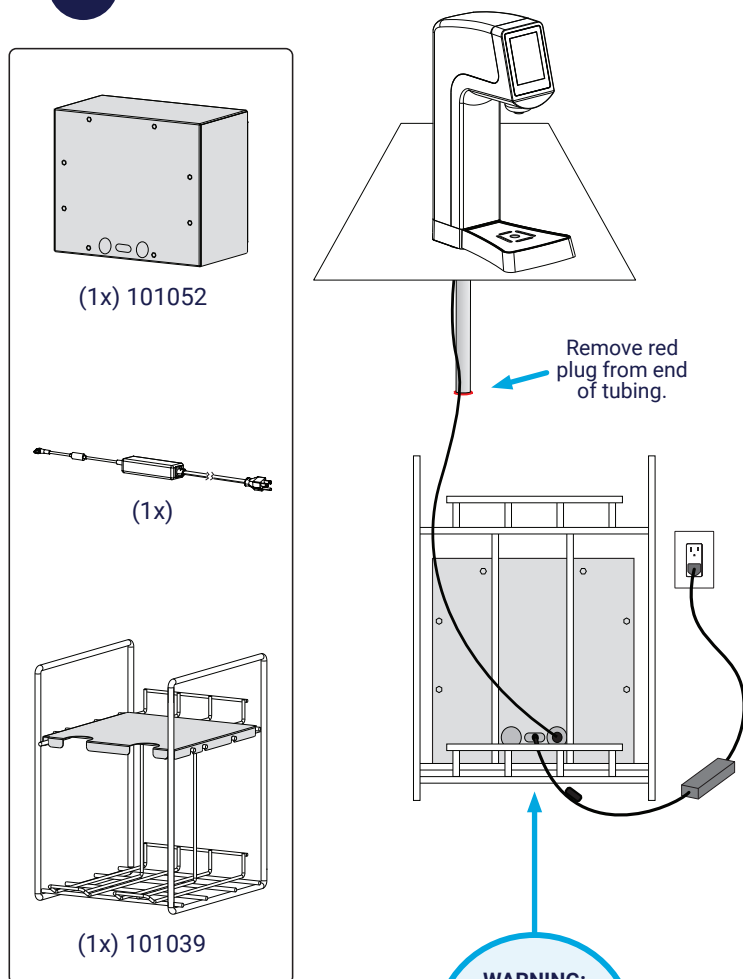

5

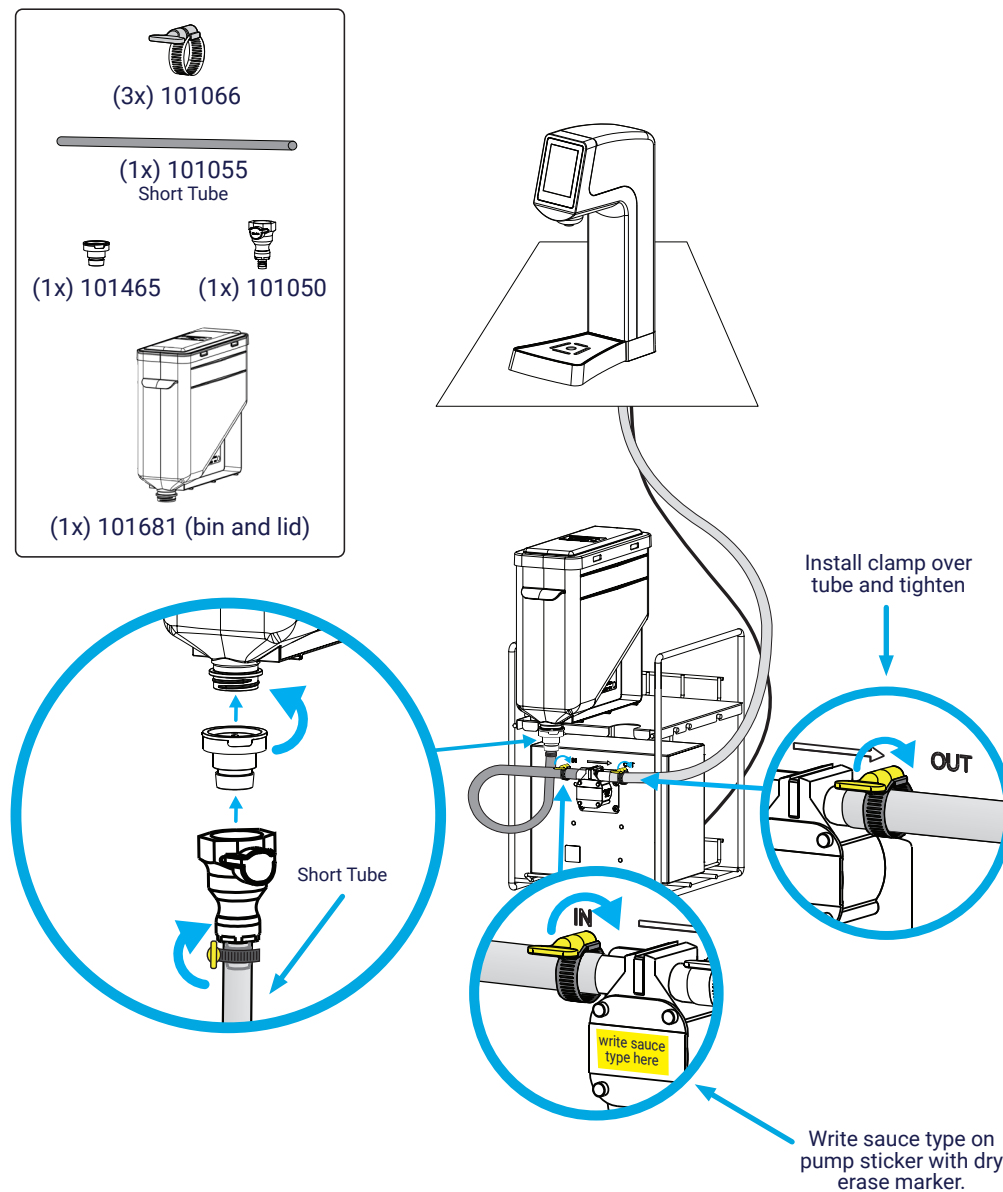

Before starting setup, you will need:

2L of Kay-5 cleaning solution per line or 2L of detergent water solution per line

Empty container for flushed sanitizer/cleaner solution

1L of rinse sanitizer per line if cleaning with detergent

Clean, dry towels

Dry erase markers



SETUP

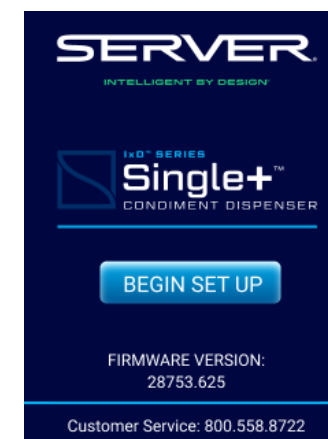

Follow prompts to continue



Scan for Single+ Condiment Dispenser manual or visit https://server-products.com/1xDM_Single.pdf

