



S E R V E R

SERVE BETTER™

CHOLULA
HOT SAUCE

Specialty Dispenser

with Eco Pump™

MODEL: SS-BP-1

- 87876** Chili Lime
- 87877** Chili Garlic
- 87878** Chipotle
- 87879** Original
- 88838** Green Pepper

For use with 64 oz
Cholula® Hot Sauce jugs



Thank You

...for purchasing this specialty stand for our Eco Pump™. This quality, NSF listed pump delivers precise portions and is a reliable alternative to the constant expense of disposable pumps.

CONSISTENT PORTIONS—SERVE BETTER

DISPENSER PARTS

UNIT MODEL: SS-BP-1

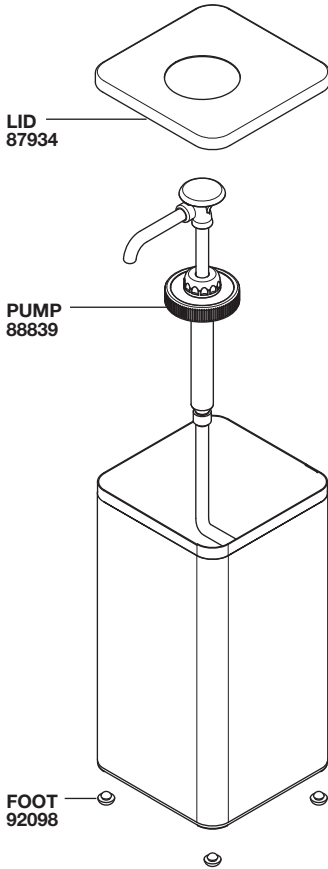

REPLACEMENT SHROUDS

(Include base, decal & feet)

- 87888 CHILI LIME
- 87889 CHILI GARLIC
- 87891 CHIPOTLE
- 87892 ORIGINAL
- 87887 GREEN PEPPER

PUMP MODEL: BP-1/4
PUMP 88839

HEAD
ASSEMBLY
88175

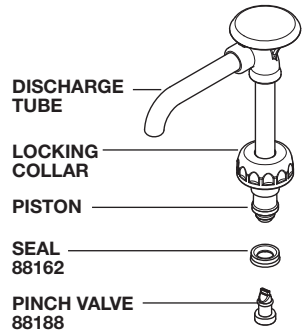

CYLINDER
ASSEMBLY
87938

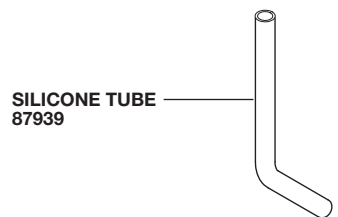
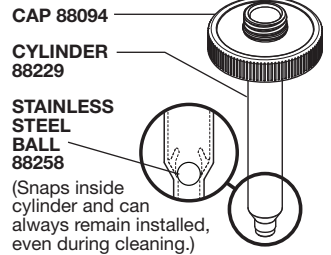

FOOD EQUIPMENT LUBRICANT
40179



21" BRUSH
82526



SAFETY



According to food and safety regulations, most foods must be stored and/or served at certain temperatures or they could become hazardous. Check with local food and safety regulators for specific guidelines.

Be aware of the product you are serving and the temperature the product is required to maintain. Server Products, Inc. cannot be responsible for the serving of potentially hazardous product.

IMPORTANT

Clean, rinse, sanitize, and dry parts daily or regularly to comply with local sanitization requirements.



NSF International lists this pump as:
"Not acceptable for dispensing potentially hazardous foods."

DISASSEMBLY

DISASSEMBLE & WASH ALL PARTS PROPERLY BEFORE USE. See page 4.

During disassembly, collect small parts in a container to prevent loss.

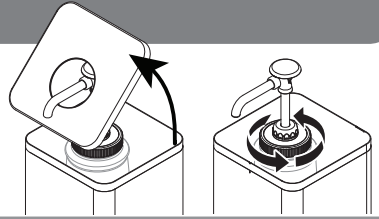

1 REMOVE LID

from shroud.

2 REMOVE PUMP

from jug of product.

3 SEPARATE CYLINDER ASSEMBLY & HEAD

Loosen locking collar to release.

4 REMOVE SPRING, CAP & SILICONE TUBE FROM CYLINDER

5 REMOVE PINCH VALVE

from head assembly.

6 REMOVE SEAL

from head assembly by pressing it down and off with thumb. Do not use a sharp tool.

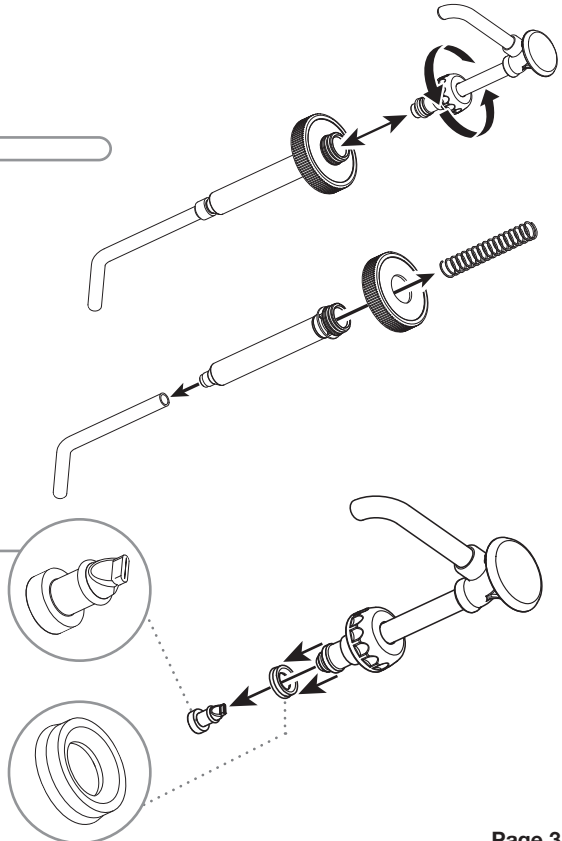

CLEANING

PUMP CLEANING

1 FLUSH & RINSE

all pump surfaces with hot water.

Place lower end of pump into container of hot water and operate pump until all remaining product is expelled and only hot water is discharged.

2 DISASSEMBLE & CLEAN

all washable parts with soap and hot water (See DISASSEMBLY on page 3.)

USE SMALL NYLON BRUSH

to thoroughly clean inside discharge tube and any confined areas.

3 RINSE

fully with clear water.

4 SANITIZE

all parts according to local sanitization requirements. All parts in contact with food must be sanitized.

5 AIR DRY

all parts fully.

YES!

Use dishwashing soap, hot water and nylon brush



Pump is dishwasher safe.

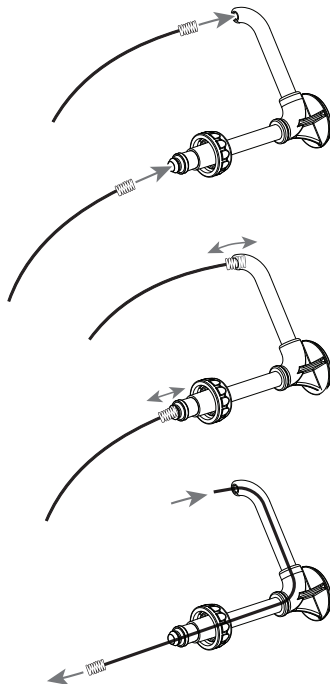

SHROUD CLEANING

Shroud may be wiped clean with dishwashing soap & hot water. Dry thoroughly.

Protect the shroud graphic. Do not immerse in water.

CLEAN-IN-PLACE PROCEDURE FOR PUMPS

1 CLEAN

- Pump out all (if any) remaining food product from inside pump body.
- Wash and rinse off outside of pump body.
- Flush out and rinse inside of pump.
- Place lower end of pump into container full of water and operate pump until all (if any) remaining product is expelled and only warm water flows from discharge tube.
- Mix 2 tsp (5 mL) of dishwashing detergent with 1 quart (.95 L) of hot tap water (approximately 110°F/43°C).
- Place lower end of pump into cleaning mixture. Pump until all cleaning mixture is expelled.

2 RINSE

- Place lower end of pump into 2 cups (.5 L) of hot tap water (approximately 110°F/43°C) and pump until all tap water is expelled.

3 SANITIZE

- Mix one 1 oz (30 mL) packet of KAY-5 Sanitizer/Cleaner (EPA REG No. 5389-15) with 2.5 gallons (9.5 L) of tap water (approximately room temperature).
- Place lower end of pump into this sanitizing mixture and repeatedly operate pump until 1 quart (.95 L) sanitizing mixture is pumped through pump.

4 RINSE

- Place lower end of pump into 1 cup (.24 L) of hot tap water (approximately 110°F/43°C) and pump until all tap water is expelled.

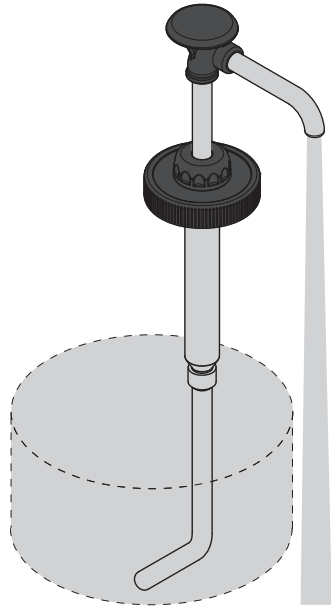

CARE OF STAINLESS STEEL

This durable unit includes stainless steel components.

If you notice corrosion beginning on any stainless steel surface, you may need to change the cleansing agent, sanitizing agent, or the cleaning procedures you are using.

- A mildly abrasive nylon or brass brush may be used to remove any stubborn deposits.

- Fully rinsing and drying all parts can help prevent corrosion. Elements and minerals in tap water can accumulate on stainless steel parts and create corrosion.
- Do not use abrasive, caustic or ammonia based cleansers.
- Do not use products containing acids, alkalines, chlorine, or salt. These agents can corrode stainless steel.
- Do not use metal scrapers or cleaning pads that could scratch surfaces.

ASSEMBLY



PRACTICE SAFETY. WASH ALL PARTS PROPERLY BEFORE USE. See page 4.

1 INSTALL SEAL

onto head assembly piston.
Apply small amount of food
equipment lubricant inside seal.

TIP:

Flared end of seal must face down.

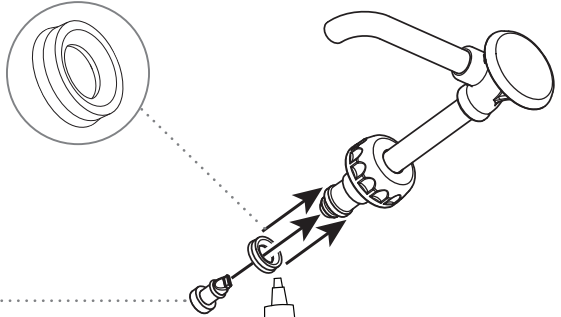

2 INSTALL PINCH VALVE

TIP: *Squeeze the pinch valve open
before installation to ensure it isn't
stuck shut.*

Install pinch valve into bottom of piston.
Press pinch valve securely to seal end.



3 INSERT SPRING

into cylinder

& ADD SILICONE TUBE
to bottom of cylinder.

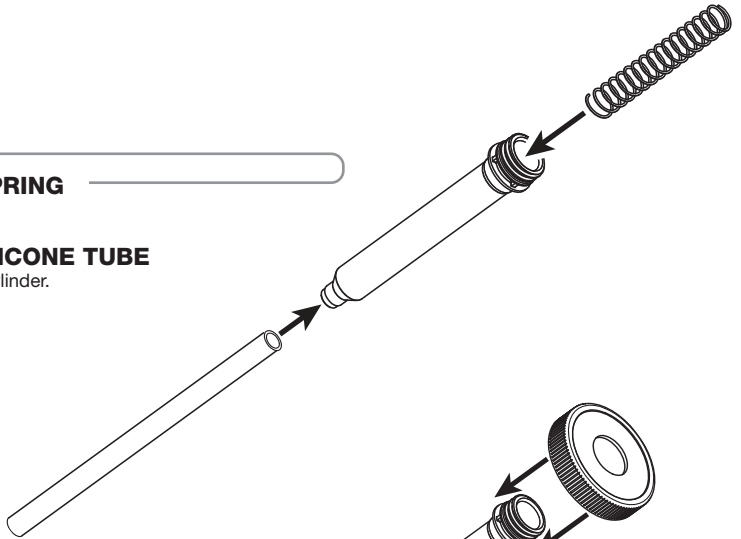

4 SNAP CAP ONTO CYLINDER

Press firmly to secure cap down
over all threading on cylinder.

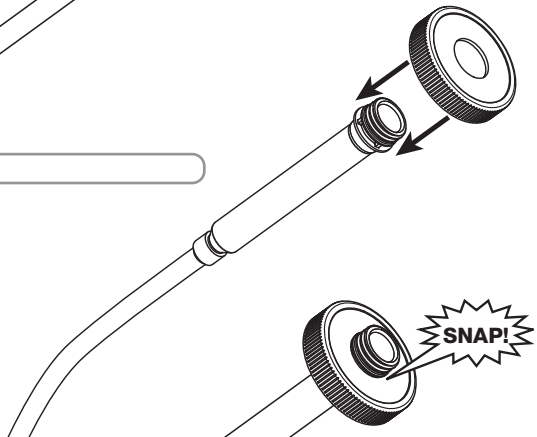

5 INSTALL HEAD ASSEMBLY INTO CYLINDER

Apply a small amount of food equipment lubricant to the outside of seal.
Slide locking collar down onto cylinder threading.
Tighten firmly to secure head assembly to cylinder.

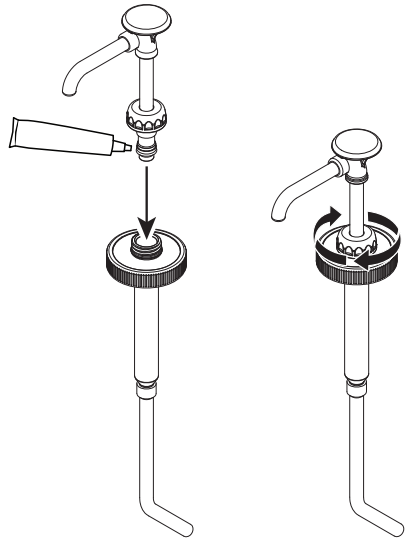

6 INSERT & SECURE PUMP

to jug of product.
Tighten cap very firmly onto product jug threading.
Place jug into shroud.

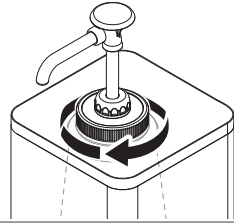

7 ADD LID

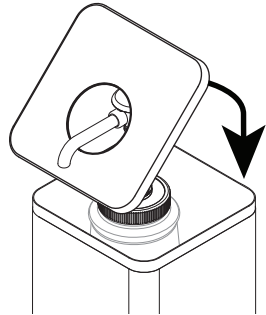

8 PRIME PUMP

Press pump several times until any air bubbles are eliminated and only product is dispensed.

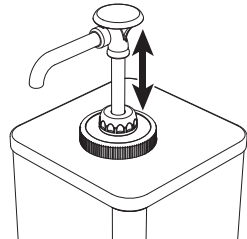

TROUBLESHOOTING

PRODUCT OZZES OUT FROM LOCKING COLLAR?

- Ensure that the **cap is securely snapped** into place below all the threading on the cylinder.

INCONSISTENT PORTIONS?

- **Clean pump.**
- Ensure product jug is not empty and has **enough product** to pump.
- Ensure unit is **assembled correctly.**

TIP: Flared end of **seal** must face down.

- Ensure **pinch valve** is installed correctly.

TIP: Squeeze the pinch valve open before installation to ensure it isn't stuck shut.

- Ensure that the **spring** is functional. Replace broken spring if necessary.

- Ensure that the **stainless steel ball** is snapped in place below tabs.

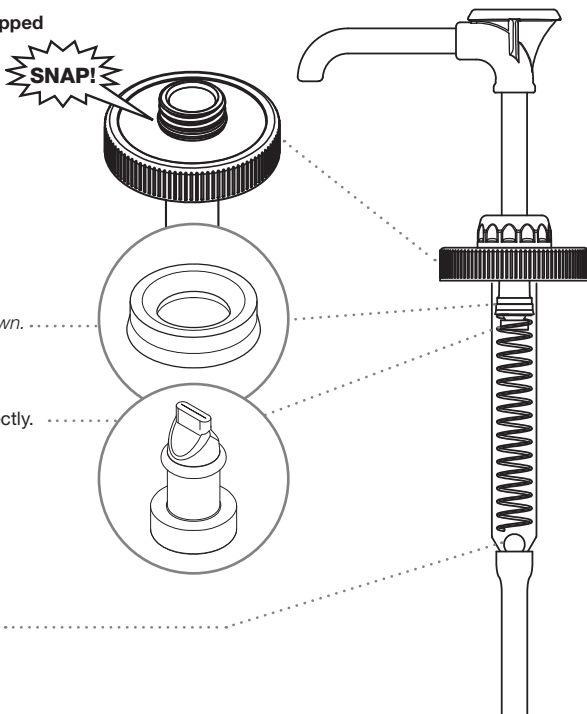

SERVER PRODUCTS LIMITED WARRANTY

2 YEAR
WARRANTY



Server Products equipment is backed by a two-year limited warranty against defects in materials and workmanship.

For complete warranty information go to:

www.Server-Products.com

GENERAL SERVICE, REPAIR OR RETURNS

Before sending any item to Server Products for service, repair, or return, contact Server Products customer service to request a **Return Authorization Number**. Merchandise must be sent to Server Products with this number. Service is extremely prompt. Typically, units are repaired and ship out within 48 hours of receipt.

Merchandise being returned for credit must be in new and unused condition and not more than 90 days old and will be subject to a 20% restocking charge.

NEED HELP?

Server Products Inc.

3601 Pleasant Hill Road
Richfield, WI 53076 USA



262.628.5600 | 800.558.8722



SPSALES@SERVER-PRODUCTS.COM

Please be prepared with your **Series Number** and **Description** located on the label inside the base.

Please refer to page 2 for individual **Part Numbers**.