

Mix-N-Serve™

MODEL: MNS

WARMER/MIXER
05578

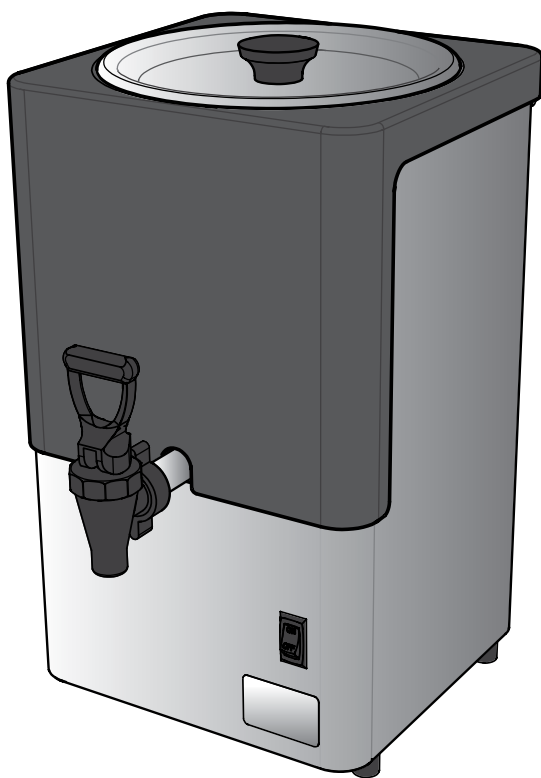

Thank You

for purchasing this Butter Warmer. This easy to clean dispenser features a magnetic impeller which continually stirs to keep melted butter uniform.

WARM, MIX & SERVE BUTTER—BETTER!

PARTS FOR 05578

MAGNET KIT
ITEM #00350472
STIR BAR KIT
05611

WARMER LID

ITEM #00350470
LID 05608

KNOB
05609

STIR BAR ASSEMBLY
05607

MAGNET
05573

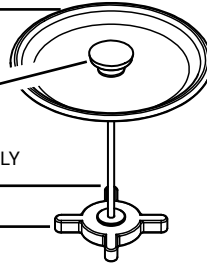

VESSEL ASSEMBLY
05557

C-RING
05576

WING NUT
05575

BUTTER SPIGOT
ITEM #000335124
FAUCET
05574

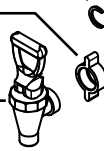

PLASTIC COVER
ITEM #00350469

COVER ASSEMBLY KIT
05615
(FOR SERIES PRIOR TO 11F, USE 05595)

BASE

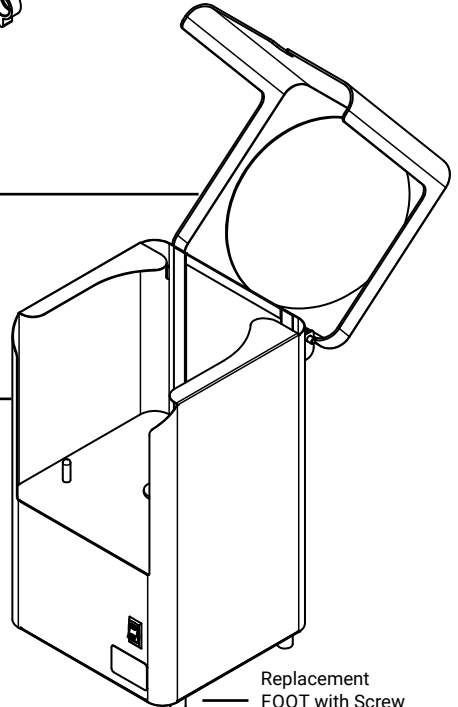

Replacement
FOOT with Screw
81058

FAUCET ASSEMBLY

WASH ALL PARTS PROPERLY
BEFORE EVERY USE. See page 6.

- 1** INSERT CUP SEAT
into faucet.



- 2** INSTALL TOP
onto faucet. Rotate clockwise to secure.

TIP: Lubricate threads with a small amount
of clean water.

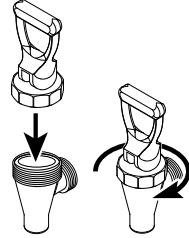

- 3** INSTALL WING NUT
onto vessel shank.

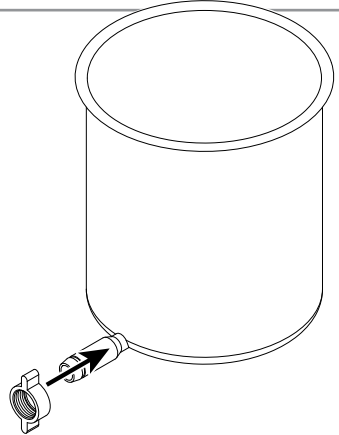

- 4** INSTALL C-RING
into shank groove.

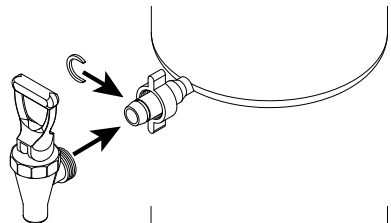

- 5** INSTALL FAUCET
Rotate wing nut counterclockwise to secure faucet
tightly onto shank.

IMPORTANT: Do not over-tighten.
This may strip threads and cause faucet
to loosen and leak.

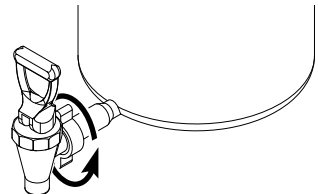

UNIT SETUP

WASH ALL PARTS PROPERLY BEFORE EVERY USE. See page 6.

- 1** ENSURE FAUCET IS SECURED to shank of vessel.
See page 3 for FAUCET ASSEMBLY

- 2** PLACE VESSEL WITH PREHEATED BUTTER INTO BASE

TIP: If solid butter is added, typical recovery time is 1 hour per pound of butter.

- 3** INSERT STIR BAR ASSEMBLY INTO VESSEL & CLOSE COVER

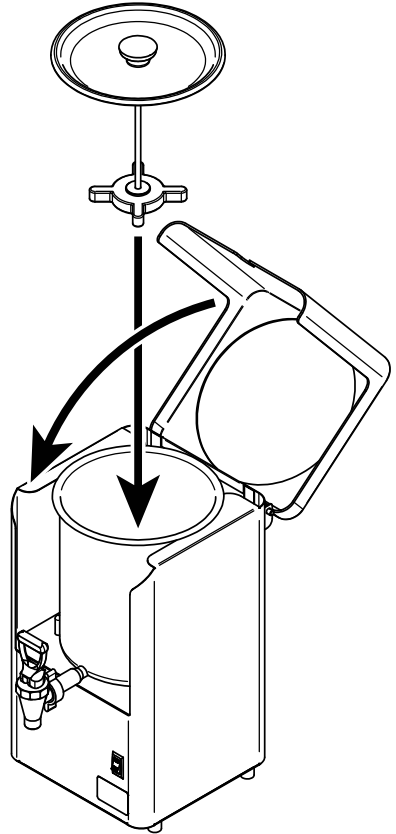

- 4** PLUG CORD into power source.

- 5** PRESS SWITCH to the "ON" position.

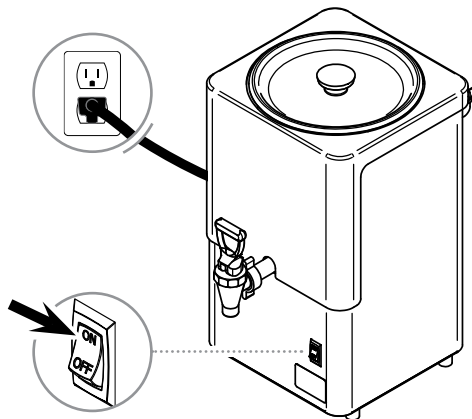

UNIT TAKE-DOWN

- 1** PRESS SWITCH to the "OFF" position.



- 2** UNPLUG CORD

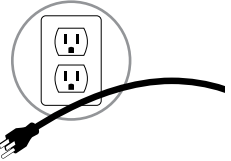

CAUTION- HOT

Allow unit to cool before continuing or use proper care with hot surfaces.

- 3** OPEN COVER,
REMOVE VESSEL
& LID

- 4** EMPTY ANY REMAINING
BUTTER
from vessel. Properly dispose butter
or pour into a storage container.

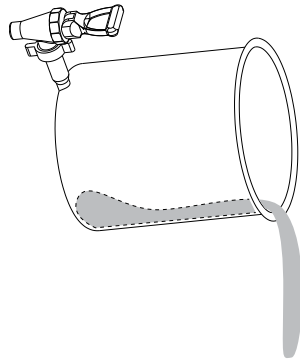

- 5** REMOVE FAUCET
Rotate wing nut clockwise to remove faucet

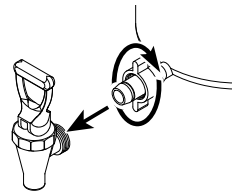

- 6** DISASSEMBLE FAUCET
Take apart all three pieces.
(Remove wingnut & C ring only if
necessary for cleaning.)

IMPORTANT:
PREVENT DRIPPING

Disassemble and clean faucet daily.

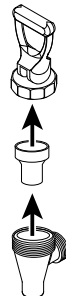

SAFETY



WARNING-

ELECTRICAL SHOCK COULD OCCUR

This unit must be earthed or grounded.

This requires all three prongs (terminals) on cord plug to be plugged into power source.



According to food and safety regulations, most foods must be stored and/or served at certain temperatures or they could become hazardous. Check with local food and safety regulators for specific guidelines.

Be aware of the product you are serving and the temperature the product is required to maintain. Server Products, Inc. can not be responsible for the serving of potentially hazardous product.

CLEANING



WARNING-

ELECTRICAL SHOCK COULD OCCUR

- Electrical components of unit could be damaged from water exposure or any liquid.
- Never immerse unit into water or any liquid.
- Never use any water jet or pressure sprayer on unit.
- Ensure unit is "OFF" and unplugged.

CAUTION- HOT

Allow unit to cool before cleaning.



CLEAN EXTERNAL SURFACES

- Wipe daily with a clean damp cloth.
- Dry with a clean soft cloth.
- Glass and surface cleaners approved for use in food contact areas may be used.



1 CLEAN

After disassembling, thoroughly clean all washable parts with soap and hot water.

2 RINSE

fully with clear water.

3 SANITIZE

all parts according to local sanitization requirements. All parts in contact with food must be sanitized.

4 DRY

Air dry faucet parts fully.

Dry stainless steel with clean, soft cloth.

CARE OF STAINLESS STEEL

This unit is constructed of stainless steel— one of the best materials for food serving and storage.

If you notice corrosion beginning on any stainless steel surface, you may need to change the cleansing agent, sanitizing agent, or the cleaning procedures you are using.

- A mildly abrasive nylon or brass brush may be used to remove any stubborn food or mineral deposits on interior surfaces of unit.
- Fully rinsing and drying all parts can help prevent corrosion. Elements and minerals in tap water can accumulate on stainless steel parts and create corrosion.
- Do not use abrasive, caustic or ammonia based cleansers.
- Do not use products containing acids, alkalines, chlorine, or salt. These agents can corrode stainless steel.
- Do not use metal scrapers or cleaning pads that could scratch surfaces.

WIRING

UNIT 05578 | SERIES 11F | 120V | USA

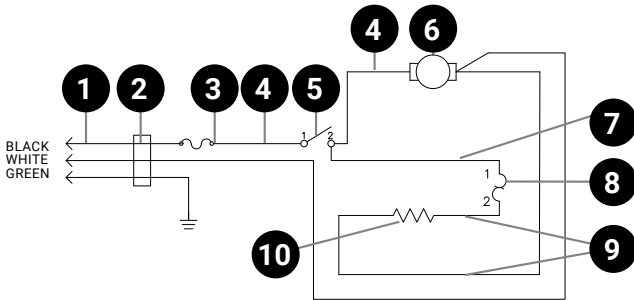

- | | | |
|---------------------------------|--------------------------------|---------------------------|
| 1 Cord Assembly | 5 Snap-In Rocker Switch | 8 Thermostat |
| 2 Bushing, Strain Relief | 6 Motor Gear | 9 Wire Assembly 8" |
| 3 Thermal Cut-Out | 7 Wire Assembly 8" | 10 Heating Element |
| 4 Wire Assembly 4" | | |

TROUBLESHOOTING

UNIT DOES NOT HEAT?

- Ensure cord is securely plugged in.
- Ensure unit is on.
- Ensure thermostat lock is set correctly.
- Ensure power is available from source.
- Do not allow any of the electrical components to get wet. Moisture may cause the unit to trip breaker or GCFI. If moisture is suspected, discontinue use. Allow unit to fully air dry.

FAUCET LEAKS?

- Fully disassemble and clean faucet daily.
- Inspect the faucet threads. If they have become stripped, replace faucet components. See page 2 for part numbers.

SERVER PRODUCTS LIMITED WARRANTY

2 YEAR
WARRANTY

This Server product is backed by a two-year limited warranty against defects in materials and workmanship. See Server-Products.com for details.

GENERAL SERVICE, REPAIR OR RETURNS

Before sending any item to Server Products for service, repair, or return, contact Server Products customer service to request a **Return Authorization Number**. Merchandise must be sent to Server Products with this number. Service is extremely prompt. Typically, units are repaired and ship out within 48 hours of receipt.

Merchandise being returned for credit must be in new and unused condition and not more than 90 days old and will be subject to a 20% restocking charge. Electrical parts (thermostats, heating elements, etc.) are not returnable.

Service Cord: Specific tools are required for safe and proper power supply cord removal and installation. If cord must be replaced, only a representative of the OEM (original equipment manufacturer) or a qualified technician may replace cord. Cord must meet code designation H05 RN-F requirements.

NEED HELP?

Server Products Inc.

3601 Pleasant Hill Road
Richfield, WI 53076 USA

Chat with us!

spsales@server-products.com

262.628.5600 | 800.558.8722

Please be prepared with your **Model, P/N** and **Series** located on the lid or base of the unit.

Example:

| | | |
|-------------------------------|---|-------------------|
| MODEL XXXX P/N ##### |  | SERIES ##X ##X |
|-------------------------------|---|-------------------|