

TWICE THE TOPPINGS. TWICE THE YUM.

TWIN TOPPING WARMERS

Manage food costs by providing precise portions of two hot toppings from #10 cans or 2.8 L jars



NSF listed as a rethermalizer – quickly heat toppings to a safe serving temperature

Precise temperature control and accurate, even heat eliminates wasted servings – no scorching as product depletes



1.800.558.8722
Outside USA: 1.262.628.5600
Server-Products.com



TWIN TOPPING WARMER Model Twin FSP

Food Applications

- Warm two sauces, gravies or toppings for dipping, dressing or plating
- Small batch prep maintains ideal freshness
- Great for heating different products that require specific temperature settings

Fast Facts

Safely warm sauces, gravies or toppings and serve with a ladle or portion-control pump – max 30 mL stroke adjusts in 3.7 mL increments.

Individual thermostats with temp markings control each heating element and use a water-bath to warm each topping. Accurate, even heat prevents scorching and burning.

Add colored, engraved knobs for quick product differentiation – specify when ordering.

TAKE ULTIMATE CONTROL OF TOPPING

TWIN HOT TOPPING WARMER

Model Twin FS, FSP & FS/FSP

Specifier Statement

Server Products Twin Topping Warmer Models Twin FS, FSP & FS/FSP are designed to heat and serve hot toppings from (2) #10 manufacturer's cans or (2) 2.8 L stainless steel jars. Number of 1 oz ladles or portion-control pumps vary by model. Maximum pump stroke dispenses 30 mL, and reduces in 3.7 mL increments. Water-bath warmers feature (2) adjustable thermostats with temperature markings to control individual 500 watt wrap-around heating elements. Temperatures range from 38°C to 93°C, and power is controlled with (2) switches. NSF listed. Rethernalizer. Two-year warranty. Ships FOB Richfield, WI 53076.

Twin Warmer Product Code

- Warmer, (2) ladles Twin FS
- Warmer, (2) pumps Twin FSP
- Warmer, (1) ladle & (1) pump Twin FS/FSP

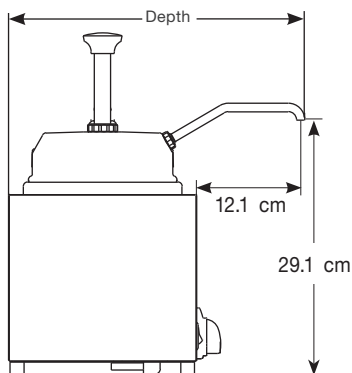
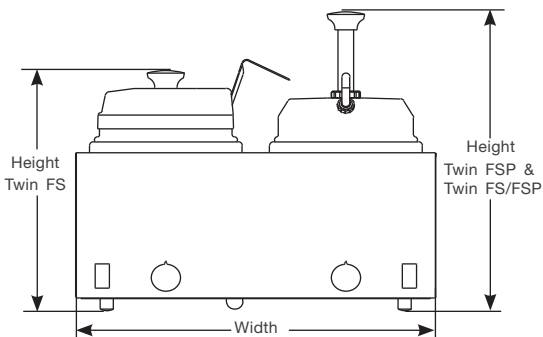

Specifications

| Model | Twin FS | Twin FSP | Twin FS/FSP |
|-----------------------|------------------------|--|---------------------------|
| | 81420 Aust | 81460 Aust | 80850 Aust |
| | | | |
| | 81250 Euro | 81260 Euro | 80280 Euro |
| | | | |
| | 84910 UK | 84990 UK | 84950 UK |
| | | | |
| | | 86943 Brazil | |
| | | | |
| Capacity | (2) 2.8 L cans or jars | (2) 2.8 L cans or jars | (2) 2.8 L cans or jars |
| Height | 31.3 cm | 38.9 cm | 38.9 cm |
| Width | 43.2 cm | 43.2 cm | 43.2 cm |
| Depth | 24.4 cm | 34.3 cm | 34.3 cm |
| Weight | 9.1 kg | 10 kg | 9.5 kg |
| Electrical | 230V 1000W 8.3A | 230V 1000W 8.3A (Brazil 4.3A) | 208-240V 1000W 8.3A |
| Single Phase, 50/60Hz | | | |



Accessory Items

- Stainless steel jar, 2.8 L 94009



Server Products, Inc. Outside of USA: 262.628.5600
 3601 Pleasant Hill Road | Richfield WI 53076
 international@server-products.com | server-products.com

Server Products, Inc. reserves the right to modify specifications without obligation.
 Printed in USA | © Server Products, Inc 01.2018 | S Twin FSP International