



S E R V E R

SERVE BETTER™

FSP Express Connection Kit

KIT 81184

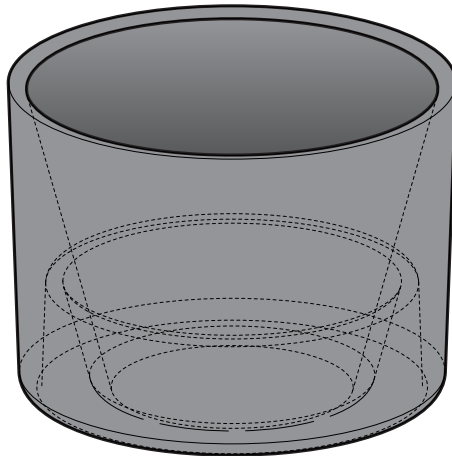
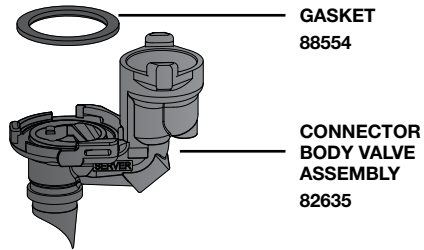

CAST ALUMINUM
POUCH SUPPORT
81181

Thank You

...for purchasing this kit to convert your existing FSP unit into a fudge or caramel pouched product dispenser. (Use a 48 oz pouch with centered 16mm fitment.) This eliminates the need of a water bath, while maintaining a consistent product temperature.

SERVE BETTER WITH DISTINCTIVE DESSERTS

DISASSEMBLY

1 PRESS SWITCH to the "OFF" position.

2 UNPLUG CORD



CAUTION- HOT
Allow unit to cool before continuing.

3 REMOVE PUMP

4 REMOVE FOOD CONTAINER & SPACER These are not needed any more.

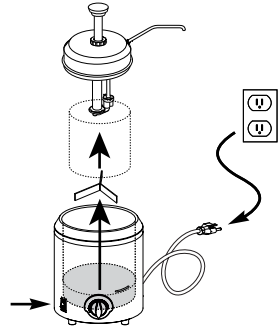

5 EMPTY WATER FROM WATER VESSEL BASIN

Thoroughly dry interior.

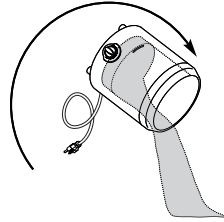

6 DISASSEMBLE & CLEAN PUMP

CLEANING

1 WASH NEW PARTS
with dishwashing soap and hot water.

2 RINSE fully with clear water.

3 SANITIZE all parts according to local sanitization requirements. All parts in contact with food must be sanitized.

4 AIR DRY all parts thoroughly.



Refer to specific manual for complete instructions included with your warming model and pump. Manuals are also available at:



www.Server-Products.com

ASSEMBLY

1 REPLACE O-RING IN PUMP

- Discard existing o-ring from lower rim of valve body.
- Install new gasket in valve body. *Flat side faces upward.*
- Reassemble pump.

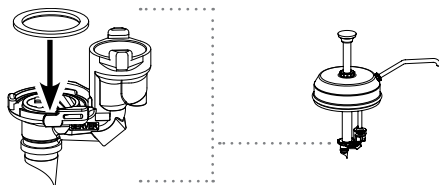

2 INSERT NEW POUCH SUPPORT

- into base of unit.
- Large opening faces upward.

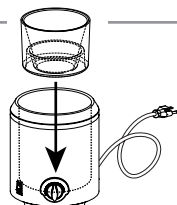

3 ATTACH PUMP TO POUCH

- Place pouch on countertop with pouch fitment circle facing upward.
- Position pump connector directly over center of pouch fitment.
- Press pump connector down to pierce through film in pouch fitment.

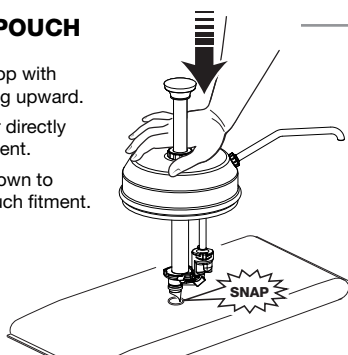

Pump is fully engaged when top surface of pouch fitment touches pump connector rim.

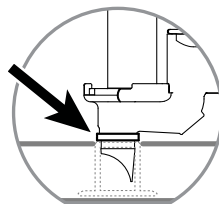

4 INSTALL PUMP & POUCH COMBO INTO WARMER

- Hold pump with pouch wrapped up around both sides of pump.

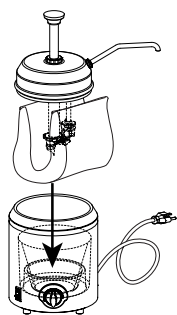

TEMPERATURE SETTING

SET TEMPERATURE KNOB 10°F (5.5°C) HIGHER THAN TARGET TEMPERATURE.

For example, if desired temperature for product in pouch is 130°F (54.5°C), set knob to 140°F (60°C).

This compensates for the new pouched system.

TROUBLESHOOTING

UNIT DOES NOT HEAT?

- Ensure cord is securely plugged in.
- Ensure power is available from source.
- Ensure unit is on.

FOOD PRODUCT NOT WARM ENOUGH?

REMEMBER...

Always set thermostat knob 10°F (5.5°C) higher than target temperature.

For example, if desired temperature for product in pouch is 130°F (54.5°C), set knob to 140°F (60°C).

This compensates for the new pouched system.

YOUR UNIT HAS AN OLDER STYLE KNOB?

Warmer series prior to 12L use a knob guard and different style knob.

Older style replacement knob: 81055

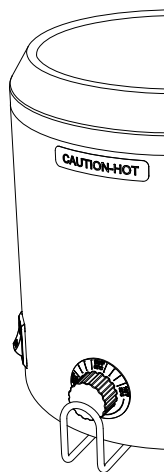

SERVER PRODUCTS LIMITED WARRANTY

2
YEAR
WARRANTY



Server Products equipment is backed by a two-year limited warranty against defects in materials and workmanship.

For complete warranty information go to:

www.Server-Products.com

GENERAL SERVICE, REPAIR OR RETURNS

Before sending any item to Server Products for service, repair, or return, contact Server Products customer service to request a **Return Authorization Number**. Merchandise must be sent to Server Products with this number. Service is extremely prompt. Typically, units are repaired and ship out within 48 hours of receipt.

Merchandise being returned for credit must be in new and unused condition and not more than 90 days old and will be subject to a 20% restocking charge. Electrical parts (thermostats, heating elements, etc.) are not returnable.

Service Cord: Specific tools are required for safe and proper power supply cord removal and installation. If cord must be replaced, only a representative of the OEM (original equipment manufacturer) or a qualified technician may replace cord. Cord must meet code designation H05 RN-F requirements.

NEED HELP?

Server Products Inc.

3601 Pleasant Hill Road
Richfield, WI 53076 USA



262.628.5600 | 800.558.8722



SPSALES@SERVER-PRODUCTS.COM

Please be prepared with your **Model, Part and Series Numbers**. This information and other important data is located on the lid and/or base of the unit.